

# Support for E280 plug-in modules

## BN , FPSU , MMP



Multi-pair boxes and supports are designed to be equipped with E280 plug-in surge protector, in order to propose solution to each kind of existing multilines installations.  
3 configurations are available :

**BN series** : Metallic enclosures for wall mounting, when no existing panel is available on the network to install E280 surge protectors. Available in 8, 16 or 32 pairs.

**FPSU series** : System built with backplane, designed to receive E280 plug-in modules, featured with terminals for line connection and equipped with specific support for mounting on MDF profiles or symmetrical DIN rail. Available for 4,8, or 16 pairs. Version with wall mounting plate : FP series (10 or 25 pairs).

BN and FPSU are equipped with different type of connection terminal : Screw, Wrapping, IDC (France), IDC (USA : Quick Connect 66 and ATT110).

**MMP module** : this connector strip, designed to receive 2 E280 surge protectors (4 pairs), is installed on MDF in mechanical adaptation with the other connectors strips. Earthing is automatically performed through the pin in contact with the metallic frame.

- **BN serie : 8, 16 or 32 pairs**  
Metal enclosures for E280
- **FPSU serie : 4, 8 or 16 pairs**  
for MDF or DIN rail mounting
- **FP series : 10 or 25 pairs**  
Wall mounting plate
- **MMP module : 4 pairs**  
Connector strip for 2 E280
- **Connection : IDC, Screw, Wrapping**

## Characteristics

Format	Metal enclosures			Supports/boards					Strip
	BN08	BN16	BN32	FPSU04	FPSU08	FPSU16	FP10	FP25	
CITEL part number	BN08	BN16	BN32	FPSU04	FPSU08	FPSU16	FP10	FP25	MMP
Max. number of pairs	8	16	32	4	8	16	10	25	4
Max. number of E280s	4	8	16	2	4	8	5	13	2
I/O connection :									
Screw terminals	BN08V	BN16V	BN32V	FPSU04V	FPSU08V	FPSU16V	-	-	-
Wrapping	BN08W	BN16W	BN32W	FPSU04W	FPSU08W	FPSU16W	-	-	-
IDC (France)	BN08CAD	BN16CAD	BN32CAD	FPSU04CAD	FPSU08CAD	FPSU16CAD	-	-	MMP
Quick connect 66 (USA)	-	-	-	-	-	-	FP10QC66	FP25QC66	-
ATT110 (USA)	-	-	-	-	-	-	FP10-110	-	-
Mounting system	Wall	Wall	Wall	MDF* DIN rail	MDF* DIN rail	MDF* DIN rail	Wall	Wall	MDF*
Earth connection	2 nuts with M4 screws			2 nuts with M4 screws					Earth pin

\* Compatible with MDF profile : PAO15001 (Infra+), HPU (3M-Pouyet), 09649 (Alcatel) and CITEL profile

# Support for E280 plug-in modules

## BN, FPSU, MMP

### Dimensions (in mm)

MMP

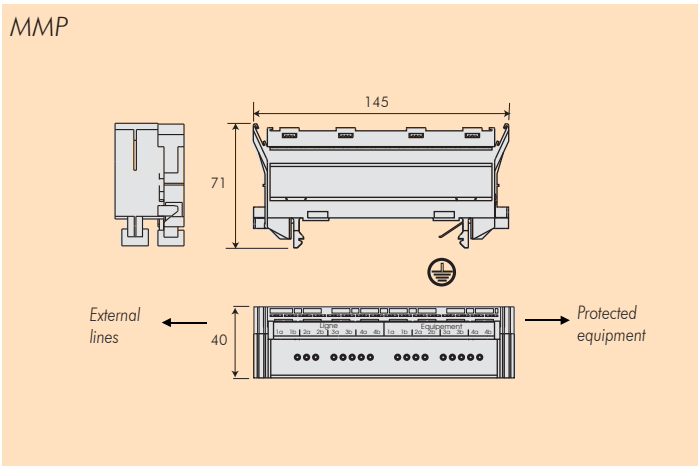

BN

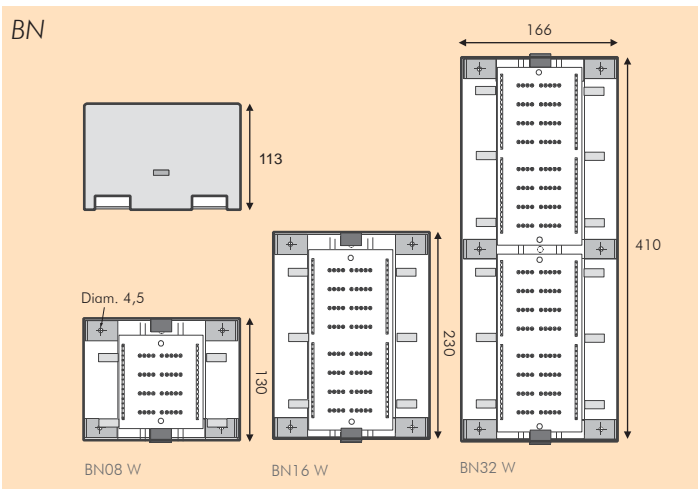

FPSU

